

Hand & mechanical directional valves

ISO 4401 sizes 06, 10, 16 and 25

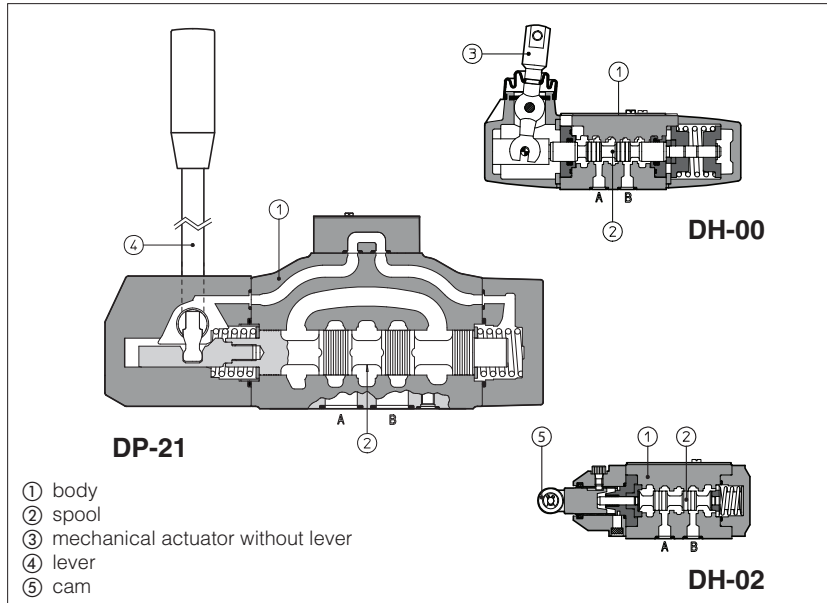

Hand & mechanical operated directional valves are spool type, three or four way, two or three position valves, available with following actuator types:

- mechanical actuator: general purpose execution for connection to customer device for the valve's remote operation
- hand-lever
- cam (only for DH and DK).

Valve sizes and max flow:

- DH-0** = size 06, flow up to 50 l/min
- DK-10 (11)** = size 10, flow up to 100 l/min
- DK-12** = size 10, flow up to 140 l/min
- DP-2** = size 16, flow up to 300 l/min
- DP-4** = size 25, flow up to 700 l/min

Max pressure:

- 350 bar** for DH-0, DP-2, DP-4
- 315 bar** for DK-1*

1 MODEL CODE

DH-0	1	1	3	/	C	/	A	**	/	*
Directional control valve, size: DH-0 = 06 DK-1 = 10 DP-2 = 16 DP-4 = 25										Seals material: - = NBR PE = FKM
Type of actuator: 0 = mechanical, without lever 1 = hand-lever 2 = cam (only for DH-0 and DK-1)										Options: /A = actuator device mounted on side of port B Lever position to be specified for DH-00, DH-01 and DK-00, DK-01 with configuration 6, 7, 8, see section 3 for hydraulic connections: /I = in rest position the lever is inclined towards the valve body * * /E = in rest position the lever is inclined in opposite side * * Only for DK-1: /Y = external drain
Valve configuration, see sections 2 and 3 0 = free, without springs 1 = spring centered, without detent 2 = return to internal position 3 = return to external position 4 = 3 position, with detent 5 = 2 external positions, with detent 6 = centre plus external positions, with detent 7 = return to external position from the centre position 8 = return to the centre position from the external position										Only for DH-01 hand-lever valves: /C = short hand - lever and reduced actuation force
										Series number
										Spool type, see section 3

2 RANGE OF VALVE'S MODELS

VALVE TYPE	SIZE	VALVE CONFIGURATION								
		0	1	2	3	4	5	6	7	8
DH-00	06	•	•	•	•	•	•	•	•	•
DH-01		•	•	•	•	•	•	•	•	•
DH-02		•	•	•	•	•	•	•	•	•
DK-10	10	•	•	•	•	•	•	•	•	•
DK-11		•	•	•	•	•	•	•	•	•
DK-12		•	•	•	•	•	•	•	•	•
DP-20	16	•	•	•	•	•	•	•	•	•
DP-21		•	•	•	•	•	•	•	•	•
DP-40		•	•	•	•	•	•	•	•	•
DP-41	25	•	•	•	•	•	•	•	•	•

DH-00*, DH-01* and DK-10*, DK-11* - mechanical and hand lever actuator

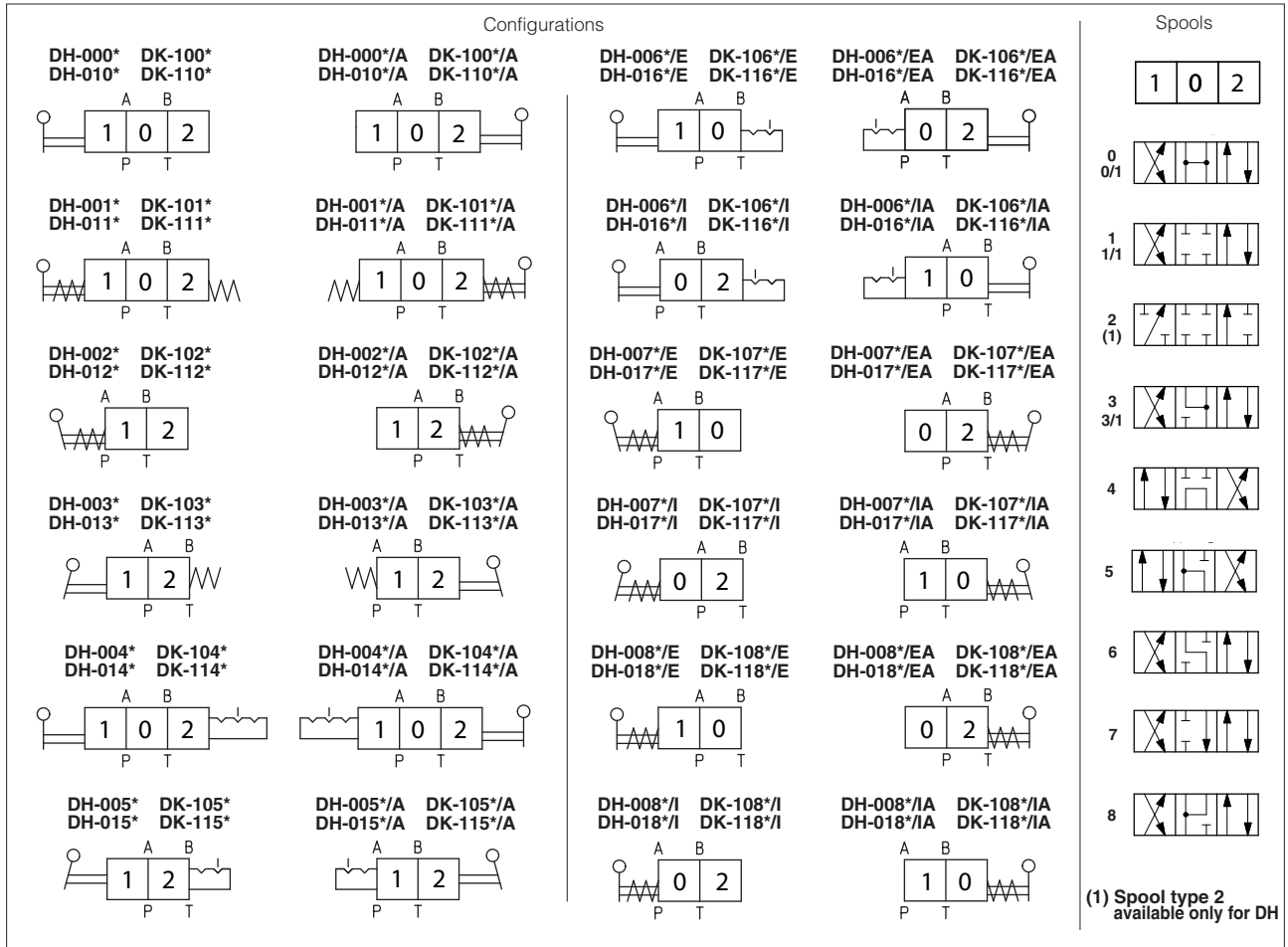

DP-20*, DP-21*, DP-40*, DP-41* - hand lever actuator

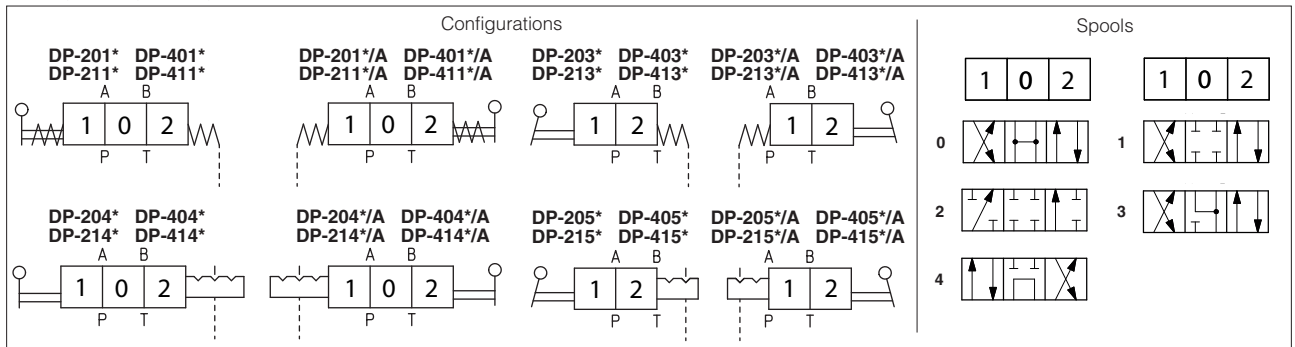

DH-02*, DK-12* - cam actuator

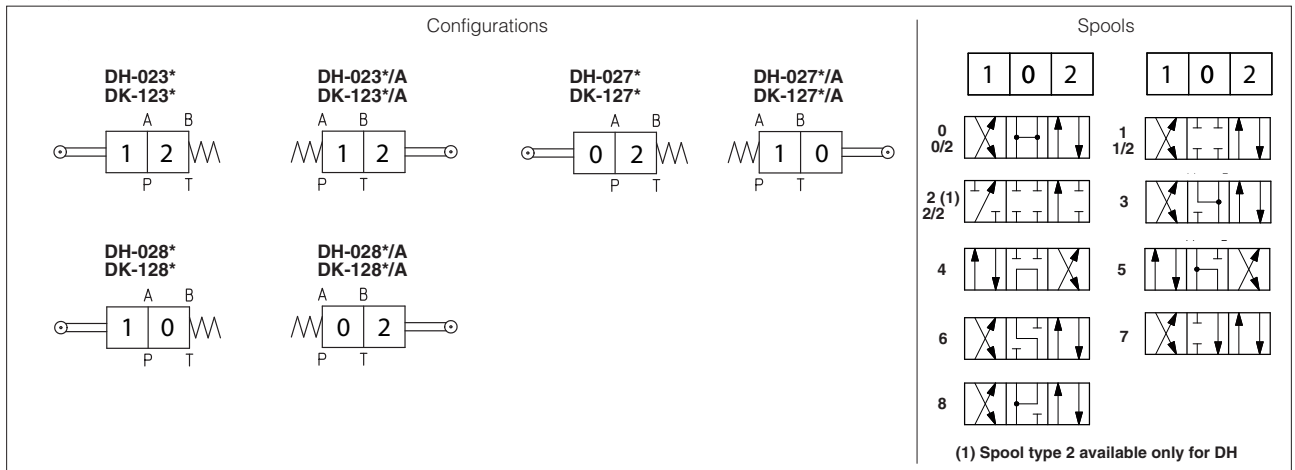

NOTE

- Spools type 0/2, 1/2, 2/2 are only used for valves type DH-023*/2 and DK 123*/2;

4 GENERAL CHARACTERISTICS

Assembly position	Any position except for configuration 7 (without spring) that must be installed with horizontal axis	
Subplate surface finishing to ISO 4401	Acceptable roughness index, Ra ≤0,8 recommended Ra 0,4 - flatness ratio 0,01/100	
MTTFd valves according to EN ISO 13849	150 years, see technical table P007	
Ambient temperature range	Standard = -30°C ÷ +70°C /PE option = -20°C ÷ +70°C	
Storage temperature range	Standard = -30°C ÷ +80°C /PE option = -20°C ÷ +80°C	
Flow direction	As shown in the symbols of tables 3	
Compliance	RoHS Directive 2011/65/EU as last update by 2015/65/EU REACH Regulation (EC) n°1907/2006	
Operating pressure	DH	P, A, B = 350 bar T = 160 bar
	DK	P, A, B = 315 bar T = 160 bar
	DP	P, A, B, X = 350 bar T = 250 bar for external drain (standard); Ports Y = 0 bar
Maximum flow	DH	50 l/min
	DK-10, DK-11	100 l/min
	DK-12	140 l/min
	DP-2 DP-4	300 l/min 700 l/min

5 SEALS AND HYDRAULIC FLUIDS - For other fluids not included in above table, consult our technical office

Seals, recommended fluid temperature	NBR seals = (standard) -30°C ÷ +80°C, with HFC hydraulic fluids = -20°C ÷ +50°C FKM seals = (/PE option) -20°C ÷ +80°C		
Recommended viscosity	15 ÷ 100 mm ² /s - max allowed range 15 ÷ 380 mm ² /s		
Max fluid contamination level	ISO4406 class 20/18/15 NAS1638 class 9, see also filter section at www.atos.com or KTF catalog		
Hydraulic fluid	Suitable seals type	Classification	Ref. Standard
Mineral oils	NBR, FKM	HL, HLP, HLPD, HVLP, HVLPD	DIN 51524
Flame resistant without water	FKM	HFDU, HFDR	ISO 12922
Flame resistant with water	NBR	HFC	

6 Q/ΔP DIAGRAMS based on mineral oil ISO VG 46 at 50°C

DH-*

Spool type \ Flow direction	P→A	P→B	A→T	B→T	P→T
	0, 0/1, 0/2	C	C	C	C
1, 1/1, 1/2	A	A	A	A	
2, 2/2, 3, 3/1	A	A	C	C	
4, 5	D	D	D	D	A
6, 7	A	A	C	A	
8	C	C	B	B	

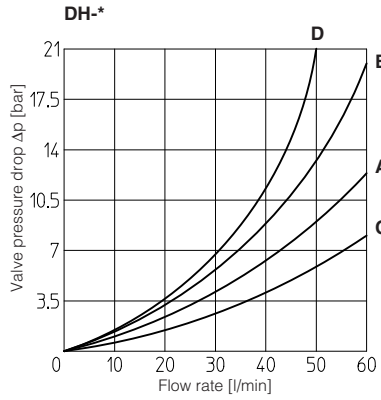

DK-*

Spool type \ Flow direction	P→A	P→B	A→T	B→T	P→T
	0, 0/1, 0/2	A	A	B	B
1, 1/1, 1/2, 6, 8	A	A	D	C	
3, 3/1, 7	A	A	C	D	
4	B	B	B	B	E
5	A	B	C	C	F

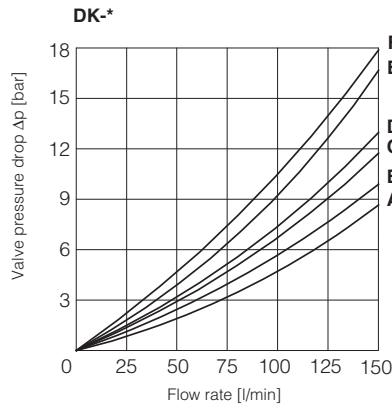

DP-2*

Spool type \ Flow direction	P→A	P→B	A→T	B→T	P→T
	1, 3	A	A	C	A
0	A	A	C	D	B
2	A	A	-	-	-
4	B	B	F	G	E

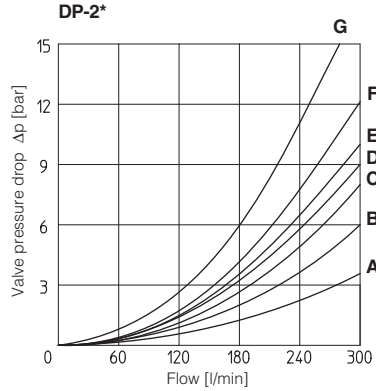

DP-4*

Spool type \ Flow direction	P→A	P→B	A→T	B→T	P→T
	1	A	A	A	C
0	C	B	C	D	E
2	A	A	-	-	-
3	A	A	C	E	-
4	B	B	F	G	G

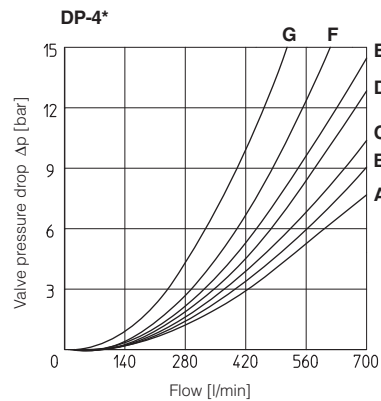

7 DIMENSIONS OF HAND & MECHANICAL OPERATED VALVES ISO 4401 SIZE 06 [mm]

DH-00**

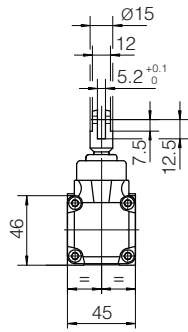
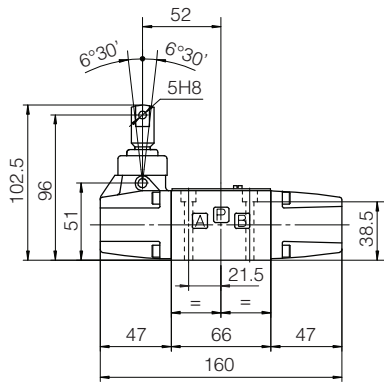

Mass: 1,2 Kg

DH-01**

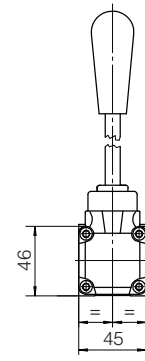
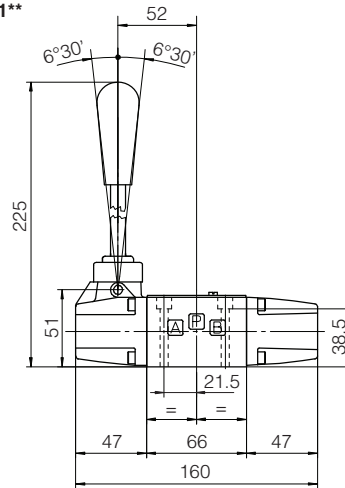

Mass: 1,6 Kg

DH-01/C**

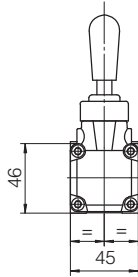
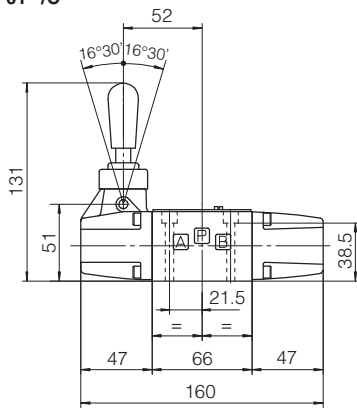

DH-02**

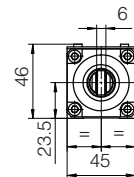
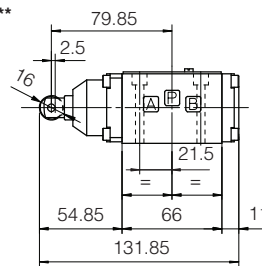

Mass: 1,2 Kg

Working stroke: 2,5 mm; extra-stroke: 0,5 mm max.

ISO 4401: 2005

Mounting surface: 4401-03-02-0-05 (see table P005)

Fastening bolts: 4 socket head screws M5x50 class 12.9

Tightening torque = 8 Nm

Diameter of ports A, B, P, T: Ø = 7,5 mm (max)

Seals: 4 OR 108

8 DIMENSIONS OF HAND & MECHANICAL OPERATED VALVES ISO 4401 SIZE 10 [mm]

DK-10**

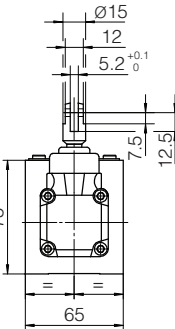
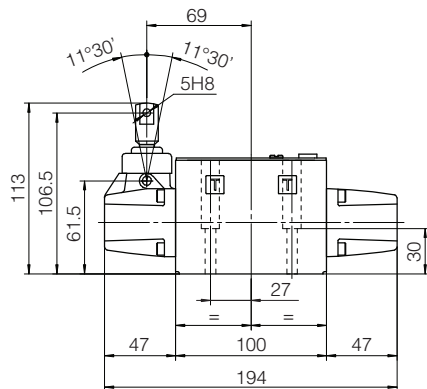

Mass: 2,5 Kg

DK-11**

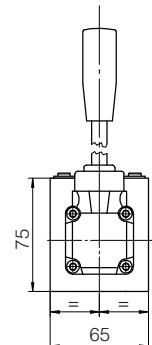
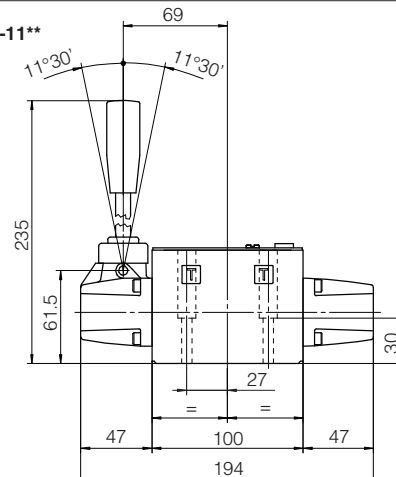

Mass: 2,8 Kg

DK-12**

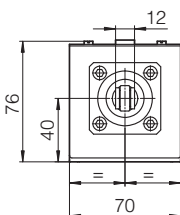
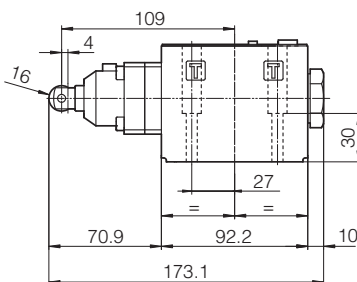

Mass: 2,5 Kg

ISO 4401: 2005

Mounting surface: 4401-05-05-0-05 (see table P005)

(Without X port, Y port optional)

Fastening bolts: 4 socket head screws M6x40 class 12.9

Tightening torque = 15 Nm

Diameter of ports A, B, P, T: Ø = 11,2 mm (max)

Seals: 5 OR 2050

Working stroke: 4 mm; extra-stroke: 0,5 mm max.

9 DIMENSIONS OF HAND & MECHANICAL OPERATED VALVES ISO 4401 SIZE 16 [mm]

DP-21

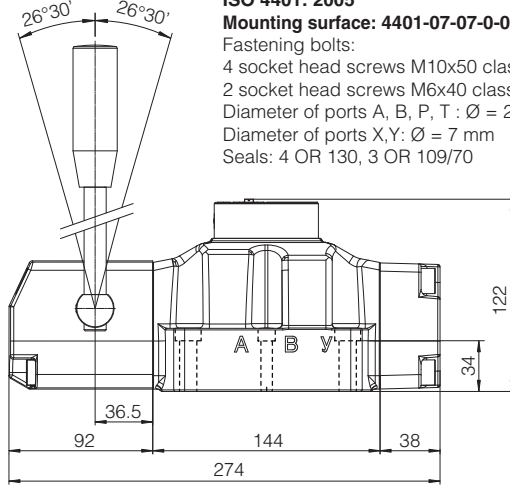

ISO 4401: 2005

Mounting surface: 4401-07-07-0-05 (see table P005)

Fastening bolts:

4 socket head screws M10x50 class 12.9, Tightening torque = 70 Nm

2 socket head screws M6x40 class 12.9, Tightening torque = 15 Nm

Diameter of ports A, B, P, T : $\varnothing = 20$ mm

Diameter of ports X,Y: $\varnothing = 7$ mm

Seals: 4 OR 130, 3 OR 109/70

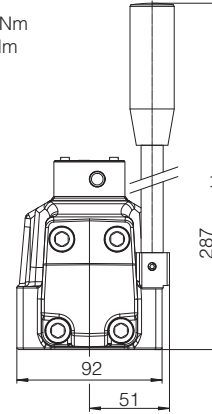

Mass: 10 Kg

DP-20

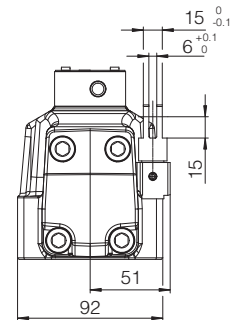
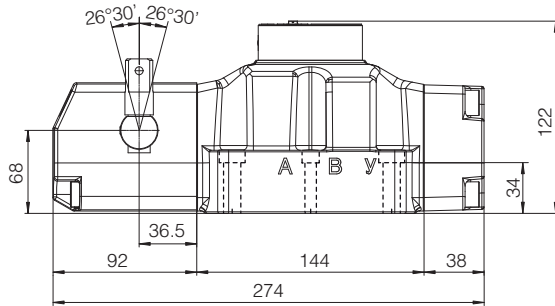

Mass: 9,7 Kg

10 DIMENSIONS OF HAND & MECHANICAL OPERATED VALVES ISO 4401 SIZE 25 [mm]

DP-41

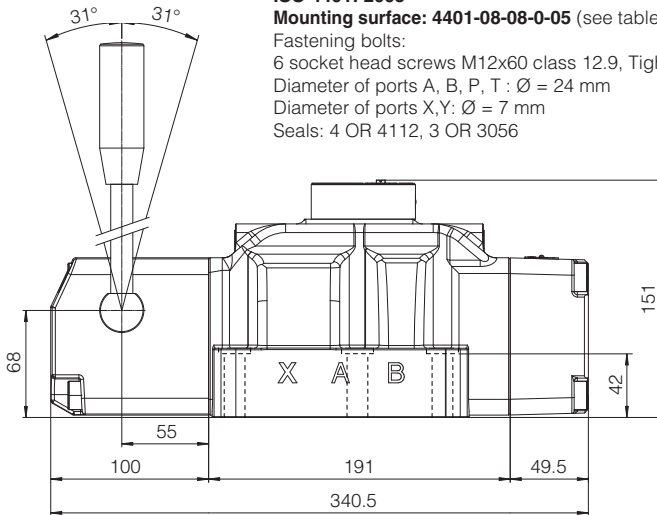

ISO 4401: 2005

Mounting surface: 4401-08-08-0-05 (see table P005)

Fastening bolts:

6 socket head screws M12x60 class 12.9, Tightening torque = 125 Nm

Diameter of ports A, B, P, T : $\varnothing = 24$ mm

Diameter of ports X,Y: $\varnothing = 7$ mm

Seals: 4 OR 4112, 3 OR 3056

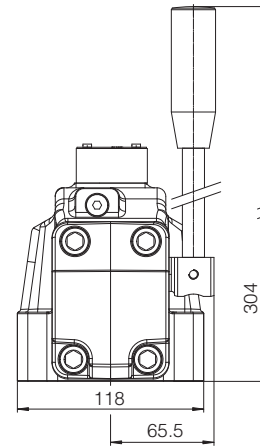

Mass: 15,5 Kg

DP-40

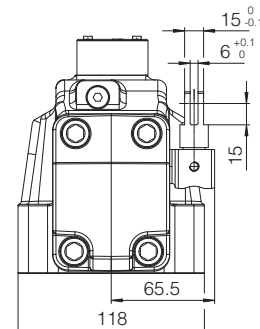
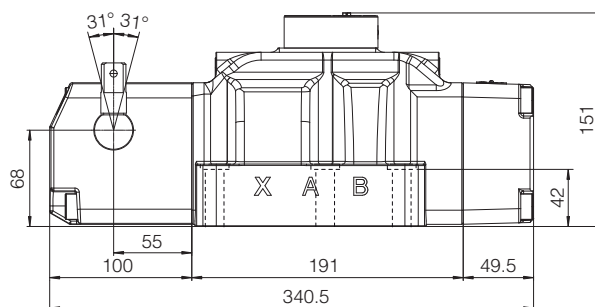

Mass: 15,2 Kg