

Programming tools for digital electronics

Atos PC software, USB adapters, cables and terminators

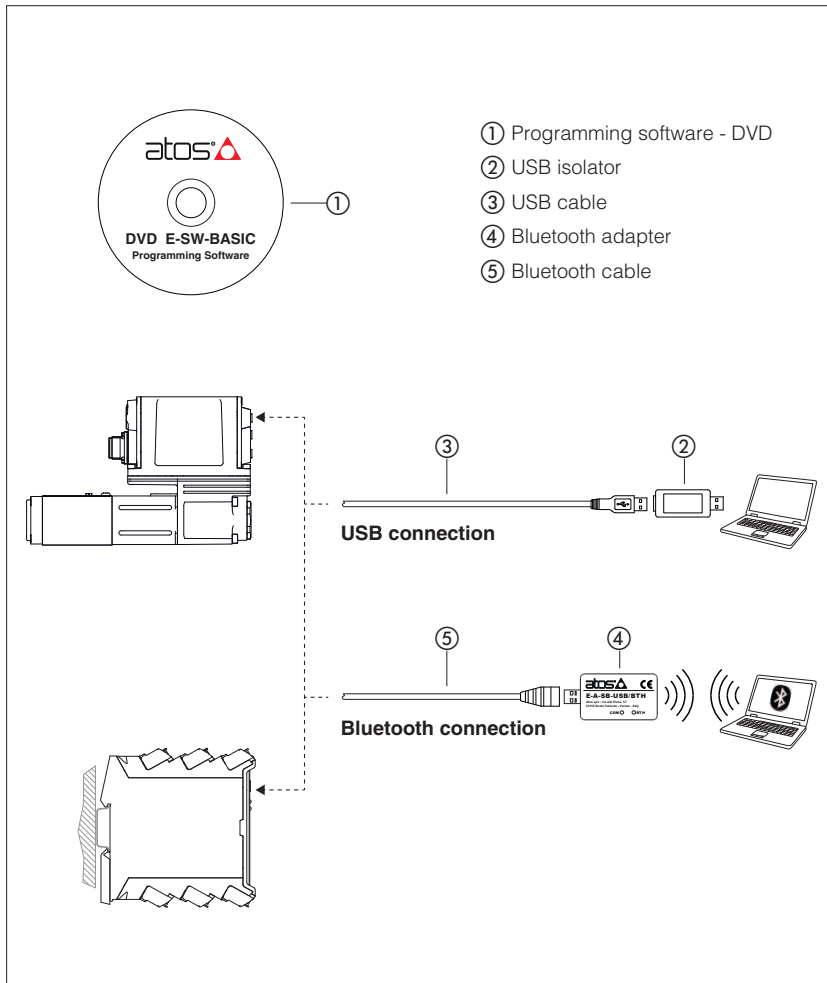

The E-SW and Z-SW programming software are supplied in DVD format and can be easily installed on a desktop or a notebook computer. The intuitive graphic interface allows:

- set up valve's functional parameters
- verify the actual working conditions
- identify and quickly solve fault conditions
- adapt the factory preset parameters to the application requirements
- store the customized setting into the valve
- archive the customized setting into the PC

The graphic interface is organized in pages related to different specific groups of functions and parameters.

The software automatically recognizes the connected valve model and adapts the displayed parameter groups, according to the selected access level.

The software is available in different versions according to the driver and axis card communication interfacing.

Fieldbus communication software includes also dedicated manuals and configuration files for user self management of the Atos electronics, using a fieldbus master.

Features:

- automatic valve recognition
- multilevel graphic interface
- numeric parameters settings (scale, bias, ramp, linearization, dither, etc.)
- real-time parameters modification
- diagnostic and monitor signals
- preset data storing into the digital driver and axis card
- internal oscilloscope function
- internal database of customized preset

DVD contents:

- software installer
- user and fieldbus communication manuals
- fieldbus configuration files

1 PROGRAMMING SOFTWARE

Valve functional parameters can be easily set up with Atos E-SW and Z-SW programming software using proper connection to the digital driver/axis card.

E - SW	-	BASIC	/	*	-	*
<p>E-SW = for valve drivers</p> <p>Supported valve drivers communication:</p> <p>BASIC = NP (USB) PS (Serial) IR (Infrared)</p> <p>FIELDBUS = BC (CANopen) BP (PROFIBUS DP) EH (EtherCAT) EW (POWERLINK) EI (EtherNet/IP) EP (PROFINET)</p>			<p>Option:</p> <p>PQ = for valve drivers with alternated P/Q controls SP, SF, SL</p>			
<p>Supplies:</p> <p>- = first supply N = next supply</p>						

Notes: E-SW-FIELDBUS supports also valve drivers without fieldbus communication;
E-SW-*/PQ supports also valve drivers without P/Q control

Z - SW	-	FULL	-	*		
<p>Z-SW = for axis cards</p> <p>Supported axis cards communication:</p> <p>FULL = NP (USB) PS (Serial) BC (CANopen) BP (PROFIBUS DP) EH (EtherCAT) EW (POWERLINK) EI (EtherNet/IP) EP (PROFINET)</p>				<p>Supplies:</p> <p>- = first supply N = next supply</p>		

1.1 Programming software versions

Different software versions are available according to the valve drivers and axis cards type to be connected and communication interface.

Note: the E-SW and Z-SW software are supplied in DVD format; E-SW-BASIC software can be free downloaded from the Atos website

Free programming software, web download:

E-SW-BASIC Software can be downloaded upon web registration at www.atos.com; service and DVD not included.
Upon web registration user receive via email the Activation Code (software free license) and login data to access Atos Download Area.
The software remains active for 10 days from the installation date and then it stops until the user inputs the Activation Code.

DVD first supply of programming software, to be ordered separately:

E-SW-BASIC Software has to be activated via web registration at www.atos.com; 1 year service included.
E-SW-BASIC/PQ Upon web registration user receive via email the Activation Code (software license) and login data to access personal Atos Download Area.
E-SW-FIELDBUS
E-SW-FIELDBUS/PQ The software remains active for 10 days from the installation date
Z-SW-FULL and then it stops until the user inputs the Activation Code.

DVD next supplies of programming software, to be ordered separately:

E-SW-BASIC-N Only for supplies after the first; service not included, web registration not allowed.
E-SW-BASIC/PQ-N Software has to be activated with Activation Code received upon first supply web registration.
E-SW-FIELDBUS-N
E-SW-FIELDBUS/PQ-N
Z-SW-FULL-N

Notes: the E-SW and Z-SW software are NOT interchangeable and have to be ordered separately;
programming software FIELDBUS and FULL can program digital electronics through USB communication port for all industrial and ex-proof versions of drivers/axis cards

1.2 DVD contents

Include software installer, user manuals and fieldbus configuration files:

EDS for BC - GSD for BP - XML for EH - XDD for EW - EDS for EI - GSDML for EP

1.3 Atos Download Area

Direct access to latest releases of programming software, manuals, USB drivers and fieldbus configuration files at www.atos.com

Software and USB drivers can be easily installed following the instruction contained in the "info.txt" files.

An automatic mailing message will inform all the registered users whenever a new software upgrade is available.

1.4 E-SW / Z-SW minimum PC requirements

Personal Computer	Pentium® processor 1GHz or equivalent	Memory	512 MB RAM + Hard Disk with 250MB free space
Operating System	Windows XP SP3	Device	DVD reader
Monitor Resolution	1024 x 768	Interface	Serial RS232 port (only for PS) or USB port

2 USB connection - ISOLATOR AND CABLE

E-SW / Z-SW software permit valve's parameterization through USB port.

2.1 Connection tools

Isolator and cables shown in the image below can be ordered individually or in a single solution purchasing a dedicated kit: **E-KIT-USB**

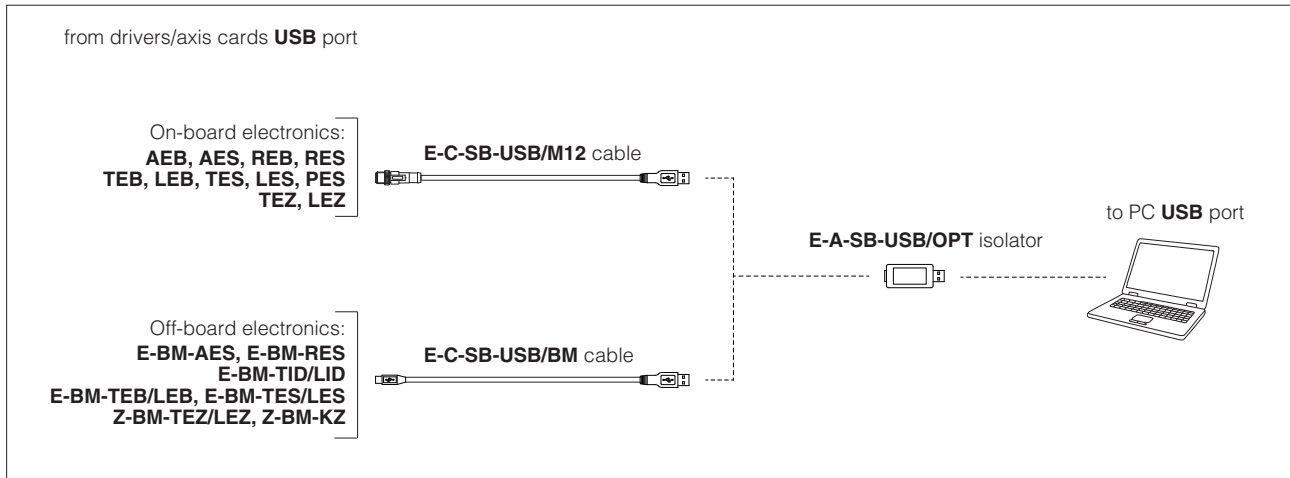

WARNING: drivers/axis cards USB port is not isolated! Use of USB isolator adapter is highly recommended for PC protection: wrong earthing connections may cause high potential difference between GNDs, generating high currents that could damage the PC connected to drivers/axis cards.

2.2 E-A-SB-USB/OPT - isolator adapter

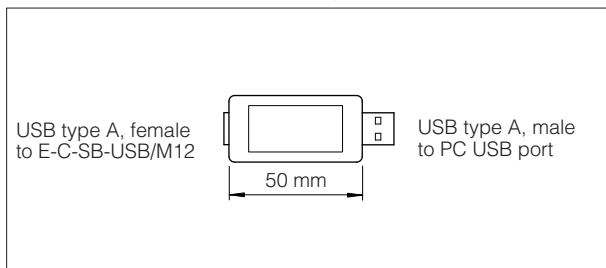

- USB 2.0 Full speed (12 MBps)
- electrical isolation 1 kV
- temperature range, $-40^{\circ} \div +50^{\circ}$ (relative humidity 25% ÷ 75%)
- external power supply not required (power 400 mA output, $5\text{ V} \pm 10\%$)
- MTBF > 1,2 million hours (MIL standard)

2.3 E-C-SB-USB/M12 - 4 m cable - only for on-board electronics

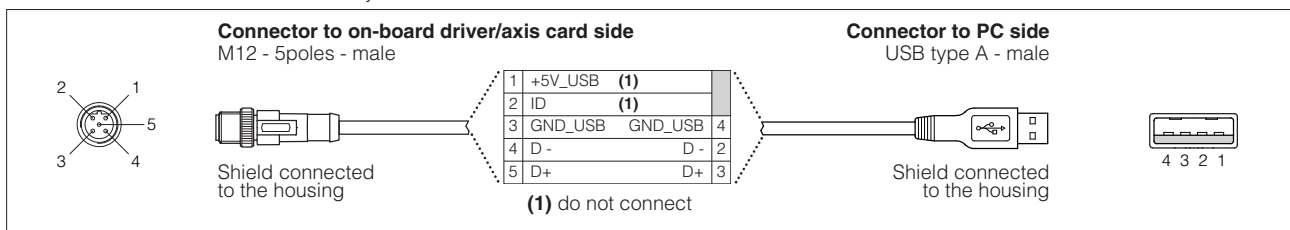

2.4 E-C-SB-USB/BM - 3 m cable - only for off-board electronics

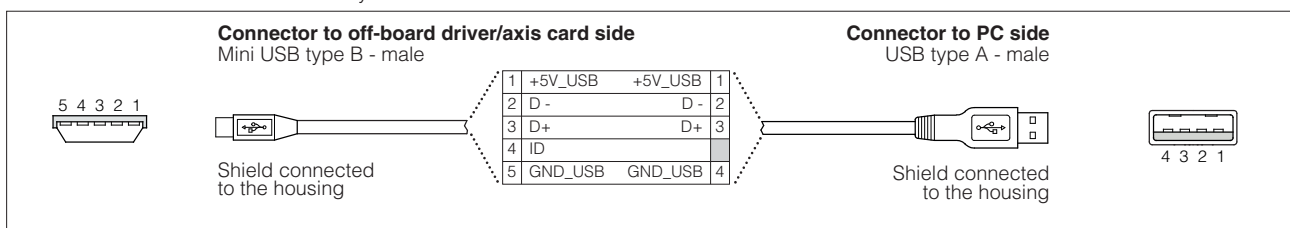

3 BLUETOOTH connection - ADAPTER AND CABLE

E-SW / Z-SW software permit valve's parameterization through Bluetooth (1).

3.1 Connection tools

Adapter and cables shown in the image below can be ordered individually or in a single solution purchasing a dedicated kit: **E-KIT-BTH**

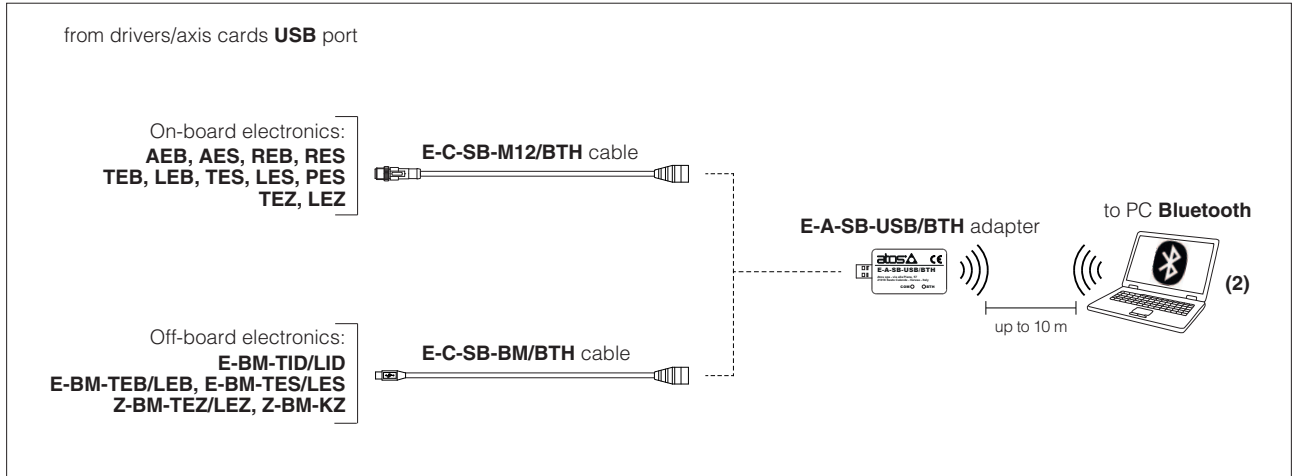

(1) Bluetooth adapter is not compatible with E-BM-AES and E-BM-RES drivers

(2) If PC has not built-in Bluetooth, use standard USB to Bluetooth dongle compatible with E-A-SB-USB/BTH specification (please refer to STARTUP-BTH guide)

3.2 E-A-SB-USB/BTH - Bluetooth adapter

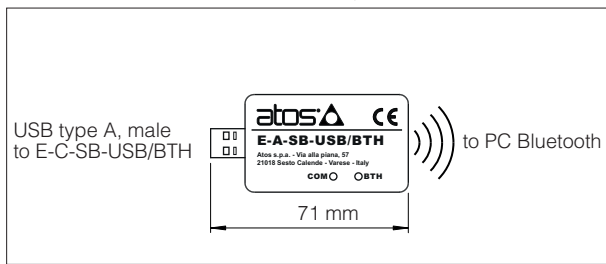

- USB male connector, type A
- type of radio interface: Bluetooth Class 2
- temperature range, $-20 \div +70$ °C (storage $-40 \div +70$ °C)
- external power supply not required (from Atos drivers/axis cards only)
- protocol: Bluetooth Classic Version 2.x , 3.x supporting Serial Port Profile
- max RF transmission power: Class 2 Output Power (+1.5 dBm typical)
- frequency: 2.402 GHz to 2.480 GHz
- LEDs indicate the actual working condition
- IP20 protection degree

WARNING: Bluetooth adapter is available only for Europe, USA, Canada, China, Japan, India, Korea markets!

Bluetooth adapter is certified according to RED (Europe), FCC (USA), ISED (Canada), SRRC (China), MIC (Japan), BIS (India), KC (Korea) directives

3.3 E-C-SB-M12/BTH - 0,4 m cable - only for on-board electronics

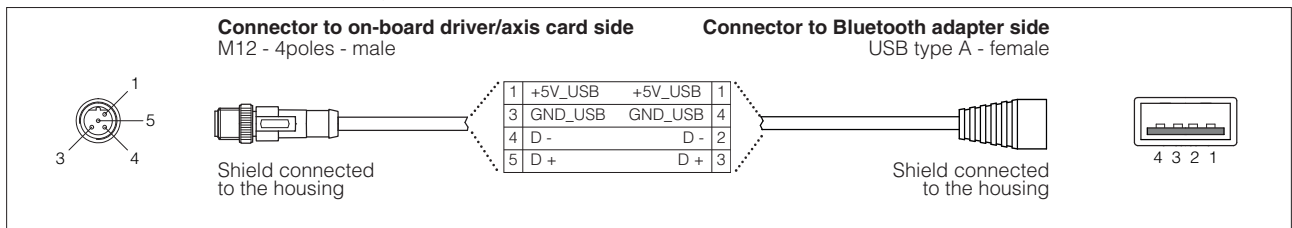

3.4 E-C-SB-BM/BTH - 0,2 m cable OTG - only for off-board electronics

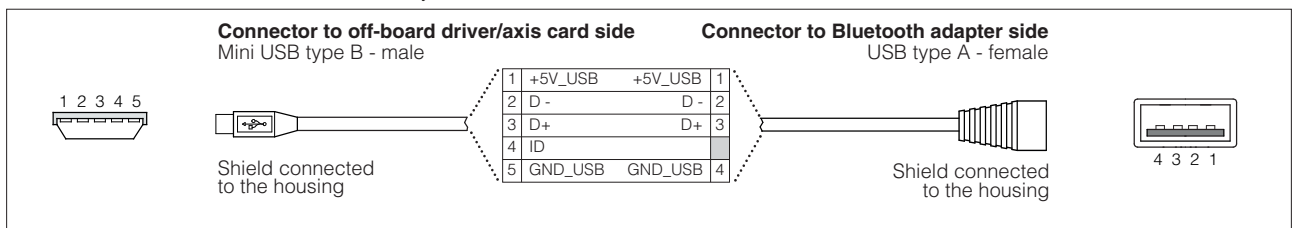

4 IR infrared - USB COMMUNICATION ADAPTER - only for **E-MI-AS-IR** drivers

The adapter have to be connected to the USB communication port of PC to activate the IR infrared communication interface towards Atos digital electrohydraulics.

4.1 Connection tools

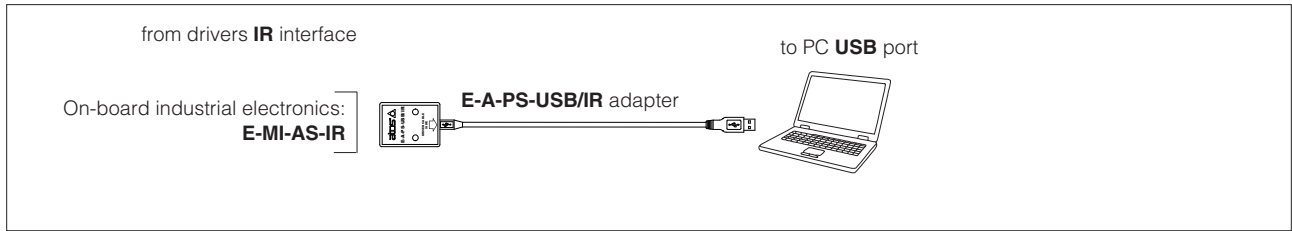

4.2 E-A-PS-USB/IR - 3 m adapter

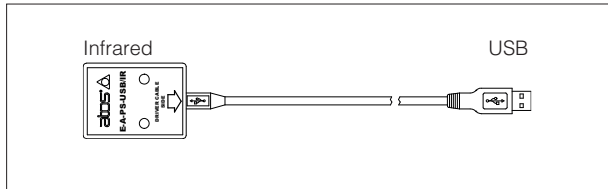

- direct infrared communication with the driver
- USB male connector, type A
- plug-in format for direct infrared connection on the driver
- transmission rate 9,6 kbit/s
- external power supply not required (USB supply)

5 PS serial RS232 - USB COMMUNICATION ADAPTER AND CROSS CABLES - only for **E-BM-AS** drivers

The adapter have to be connected to the USB communication port of PC to activate the PS serial RS232 communication interface towards Atos digital electrohydraulics. The cross cables connect the relevant connector of the USB adapter with the communication port of the digital drivers.

5.1 Connection tools

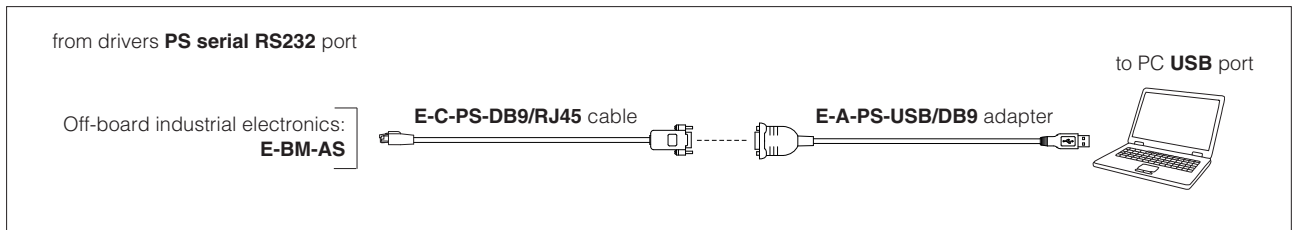

Note: the adapter is not required if PC is already equipped with a serial RS232 communication port

5.2 E-A-PS-USB/DB9 - 0,45 m adapter

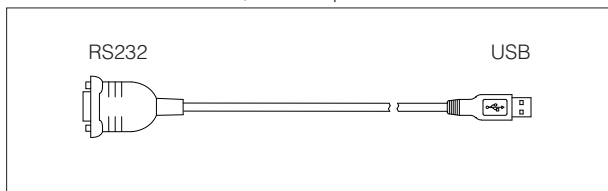

- DB9 male connector according to serial RS232 specification
- USB male connector, type A
- transmission rate from 1,6 kbit/s up to 225 kbit/s
- external power supply not required (USB supply)

5.3 E-C-PS-DB9/RJ45 - 2,5 m cable

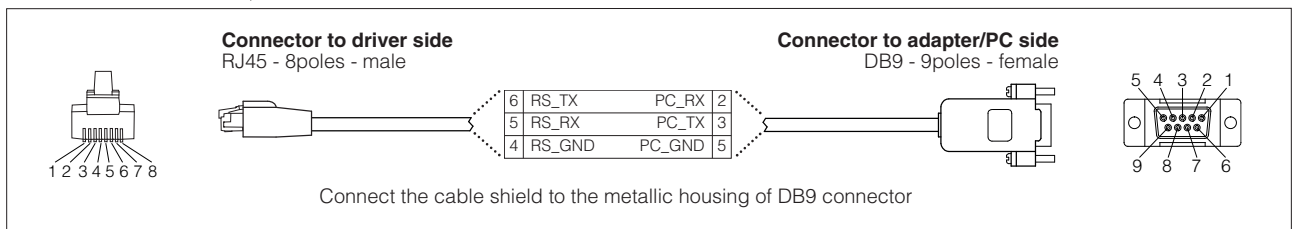

6 FIELDBUS TERMINATORS - only for BC and BP

The fieldbus terminators are required when output fieldbus connector has to be used as network end point.

Note: fieldbus terminators not available for ex-proof electronics

E - TRM	-	BC	-	M12	/	5PM
Terminator						Connector: 5PM = to BC executions (1) 4PF = to BP executions (1) DB9 = to DB9 connector, cable side (2)
Fieldbus interfaces: BC = CANopen BP = PROFIBUS DP						Connector: M12 = from M12 output fieldbus connector (1) DB9 = from DB9 connector, adapter side (2)

(1) for on-board TES, LES, PES, TEZ, LEZ series 40 or higher

(2) for off-board E-BM-AES, E-BM-RES, E-BM-TID/LID, E-BM-TEB/LEB, E-BM-TES/LES, Z-BM-TEZ/LEZ, Z-BM-KZ

6.1 M12 terminators

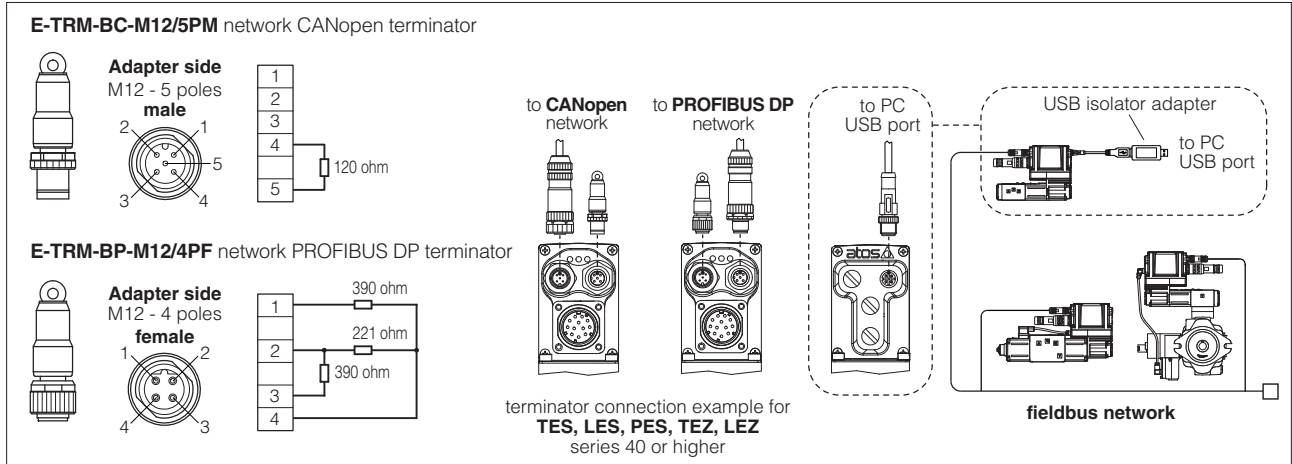

6.2 DB9 terminators

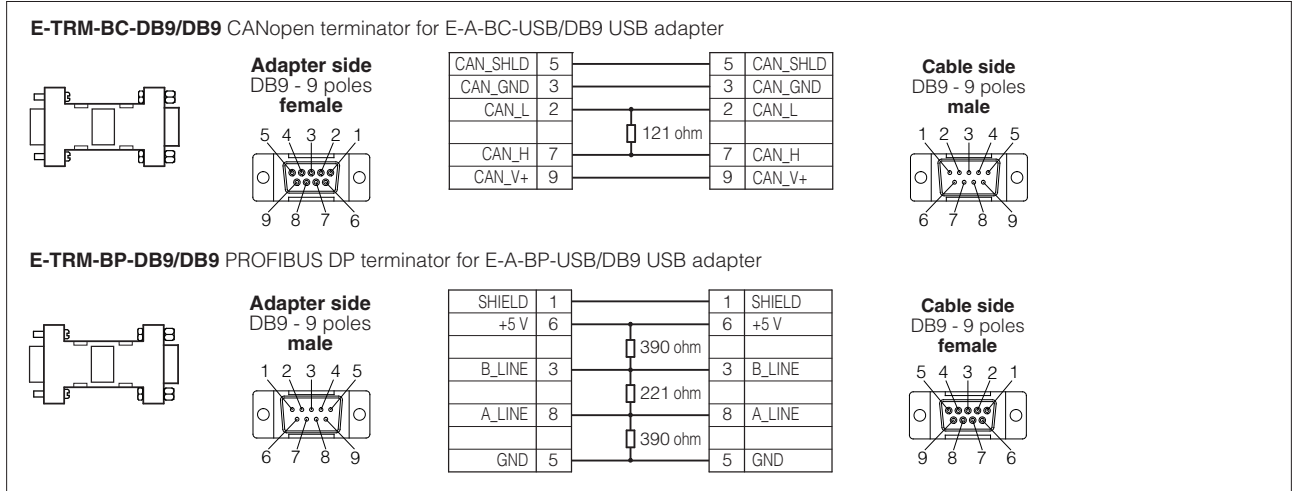

7 FIRMWARE UPDATE

It is possible to update the firmware of the following digital drivers and axis cards, using proper USB communication port. The firmware update is allowed starting from electronics series listed into the table or higher series:

Industrial electronics

E-RI-AEB s10 E-RI-AES s40	E-RI-REB s10 E-RI-RES s10	E-RI-TEB s10 E-RI-LEB s10	E-RI-TES s40 E-RI-LES s40	E-RI-TES-S s40 E-RI-LES-S s40	E-RI-PES-S s40
E-BM-AES s10	E-BM-RES s10	E-BM-TID s10 E-BM-LID s10	E-BM-TEB s10 E-BM-LEB s10	E-BM-TES s10 E-BM-LES s10	E-BM-TES-S s10 E-BM-LES-S s10
Z-RI-TEZ s40 Z-RI-LEZ s40	Z-BM-KZ s10	Z-BM-TEZ s10 Z-BM-LEZ s10			

Ex-proof electronics

E-RA-AES s40	E-RA-RES s40	E-RA-TES s40 E-RA-LES s40	E-RA-TES-S s40 E-RA-LES-S s40
Z-RA-TEZ s40 Z-RA-LEZ s40	Z-RA-TEZ-S s40 Z-RA-LEZ-S s40		

8 RECOMMENDED TOOLS SELECTION

8.1 Industrial and ex-proof electronics

	Model Code	Series	Software	Cable	USB Adapter	Terminator
IR	E-MI-AS-IR	11			E-A-PS-USB/IR	
PS	E-BM-AS	10 or higher		E-C-PS-DB9/RJ45	E-A-PS-USB/DB9	
NP	E-BM-AES, E-BM-RES	10 or higher	E-SW-BASIC	E-C-SB-USB/BM	E-A-SB-USB/OPT	
	E-BM-TID, E-BM-LID (1)	10 or higher				
	E-BM-TEB, E-BM-LEB, E-BM-TES, E-BM-LES (1)	10 or higher				
	AEB, REB (1)	10 or higher	E-SW-BASIC/PQ	E-C-SB-USB/M12		
	TEB, LEB (1)	10 or higher				
	TES, LES (1)	40 or higher	Z-SW-FULL	E-C-SB-USB/M12		
	TES, LES, PES with SP, SF, SL options (1)	40 or higher				
	E-BM-TEB, E-BM-LES with SP, SF, SL options (1)	10 or higher				
	TEZ, LEZ (1)	40 or higher	E-C-SB-USB/BM			
Z-BM-KZ, Z-BM-TEZ, Z-BM-LEZ (1)	10 or higher					
BP BC EH	E-BM-AES, E-BM-RES	10 or higher	E-SW-FIELDBUS	E-C-SB-USB/BM	E-A-SB-USB/OPT	
	RES (1)	10 or higher		E-C-SB-USB/M12		
	AES (1)	40 or higher				
BC BP EH EW EI EP	E-BM-TEB, E-BM-LES (1)	10 or higher	E-SW-FIELDBUS	E-C-SB-USB/BM	E-A-SB-USB/OPT	
	TES, LES (1)	40 or higher		E-C-SB-USB/M12		
	E-BM-TEB, E-BM-LES with SP, SF, SL options (1)	10 or higher	E-SW-FIELDBUS/PQ	E-C-SB-USB/BM		
	TES, LES, PES with SP, SF, SL options (1)	40 or higher		E-C-SB-USB/M12		
	TEZ, LEZ (1)	40 or higher	Z-SW-FULL	E-C-SB-USB/M12		
	Z-BM-KZ, Z-BM-TEZ, Z-BM-LEZ (1)	10 or higher		E-C-SB-USB/BM		

(1) Drivers and axis cards compatible with Bluetooth adapter E-A-SB-USB/BTH (see 3.1)

8.2 Obsolete industrial electronics

	Model Code	Series	Software	Cable	USB Adapter	Terminator
IR	E-MI-AS-IR	10	E-SW-IR		E-A-PS-USB/IR	
PS	AES	30	E-SW-BASIC	E-C-PS-DB9/M12	E-A-PS-USB/DB9	
	AERS, TERS, TES, LES	31				
	TES, LES, PES with SP, SF, SL options	31	E-SW-BASIC/PQ			
	TEZ, LEZ	10	Z-SW-FULL			
	Z-ME-KZ-PS	10 or higher				
BP	AES	30	E-SW-FIELDBUS	E-C-PS-DB9/M12	E-A-PS-USB/DB9	E-TRM-BP-DB9/DB9
	AERS, TERS, TES, LES	31				
	TES, LES, PES with SP, SF, SL options	31	E-SW-FIELDBUS/PQ	E-C-BP-DB9/M12		
	TEZ, LEZ	10	Z-SW-FULL	E-C-PS-DB9/DB9		
	Z-ME-KZ-PS/BP	10 or higher				
BC	AES	30	E-SW-FIELDBUS	E-C-PS-DB9/M12	E-A-PS-USB/DB9	E-TRM-BC-DB9/DB9
	AERS, TERS, TES, LES	31				
	TES, LES, PES with SP, SF, SL options	31	E-SW-FIELDBUS/PQ	E-C-BC-DB9/M12		
	TEZ, LEZ	10	Z-SW-FULL			
EH	AES	30	E-SW-FIELDBUS	E-C-PS-DB9/M12	E-A-PS-USB/DB9	

8.3 Obsolete ex-proof electronics

	Model Code	Series	Software	Cable	USB Adapter	Terminator
PS	AES	30	E-SW-BASIC	E-C-PS-DB9/M8	E-A-PS-USB/DB9	
	AERS, TERS, TES, LES	31				
BP	AES	30	E-SW-FIELDBUS	E-C-PS-DB9/M8	E-A-PS-USB/DB9	E-TRM-BP-DB9/DB9
	AERS, TERS, TES, LES	31		E-C-BP-DB9/RA	E-A-BP-USB/DB9	
BC	AES	30		E-C-PS-DB9/M8	E-A-PS-USB/DB9	E-TRM-BC-DB9/DB9
	AERS, TERS, TES, LES	31		E-C-BC-DB9/RA	E-A-BC-USB/DB9	